

WOODWORKER'S JOURNAL

downloadable plans:
"America's leading woodworking authority"™

In this plan you will be getting:

- Step by Step construction instruction.
- A complete bill of materials.
- Exploded view and elevation drawings.
- How-to photos with instructive captions.
- Tips to help you complete the project and become a better woodworker.



To download these plans, you will need **Adobe Reader** installed on your computer. If you want to get a free copy, you can get it at: **Adobe Reader**.

Having trouble downloading the plans?

- If you're using Microsoft Internet Explorer, right click on the download link and select "Save Target As" to download to your local drive.
- If you're using Netscape, right click on the download link and select "Save Link As" to download to your local drive.

WOODWORKER'S JOURNAL
©2007 ALL RIGHTS RESERVED

A Gardener's Bench



Published in Woodworker's Journal "Woodworking Secrets: Essential Methods and Projects for Fine-Tuning Your Shop Skills"

\$7.95

WJ148



A Gardener's Bench

Just as your woodshop needs a good workbench, the gardener in your household will work more effectively with a sturdy gardening bench. Ours is made of white oak and features a removable mixing tub, hidden potting tray and plenty of room for storing pots and gardening tools. If spring is nearly sprung where you live, set aside a couple weekends to build this project so you'll be ready for it.

This fine piece of outdoor furniture says one thing loud and clear: Style and grace aren't always the victims of durability. It features a removable mixing tub, a hidden potting tray, lots of room for storing extra clay pots or even bags of fertilizer, and a rack to hang plenty of gardening utensils. The bench also is designed and built to take whatever you and Mother Nature can throw at it. Even if you don't leave it outdoors, you'll want your potting bench to stand up to humidity and bugs. Virtually all the wood on ours is white oak, a good choice for outdoor applications. White oak's pores are filled with tyloses, which give the wood water-resistant properties. It also contains tannic acids, which protect the wood from insect and fungi attacks. There are alternatives to white oak, of course, like cedar, redwood, cypress, Honduras mahogany, teak or even pressure-treated pine.

While tannic acid can be beneficial, it also can cause problems. Mix tannic acid, a little humidity and regular steel screws and you've got the perfect recipe for unsightly stains. That's why we opted



Figure 2: Cut the 45° miters on the bottom aprons using a miter saw. Nibble at the cut to prevent your saw from flinging small pieces of oak across the room.

for exterior-grade screws, even where they're covered with plugs. Be sure to also use a weatherproof glue or epoxy and spar varnish for the final topcoat.

Starting with the Bench Top

Start this project by making the rather massive bench top (piece 1). Make the top from two pieces of

4½"-wide oak sandwiched around four pieces of 3½"-wide stock.

Here's a handy technique to achieve flawless butt joints without worrying if your jointer is set precisely at 90 degrees: Cut your stock to rough width and length, then arrange the boards to alternate the growth-ring patterns (see *illustration*, page 123).



Figure 3: Cut the mixing tub hole to shape with a jigsaw. Cut three sides of the hole, then screw a holding bracket to the waste so it doesn't pinch your blade or fall out while you cut the fourth side.

Number the boards so they stay in sequence and mark alternate "A's" (Away from the fence) and "O's" (On the fence) along the joint lines on the top face. With each board's top face away from the fence, joint the "A" edges. Then, with each board's top face on the fence, joint the "O" edges. This way, if your "A" cuts are 89°, you'll be guaranteed that your "O" cuts will be 91° and you'll end up with a nice flat top.

Standard biscuits aren't made for exterior applications, so we opted to join the boards with white oak splines (pieces 2). Use a dado set on your table saw to cut the grooves three inches short of each end, and finish up this step by gluing and clamping the top.

The most difficult and time-consuming step in making a large table top is flattening the glued-up panel. Scrape the joints clean of glue first with a paint scraper, then switch to a jointer plane or belt sander to level any mismatched seams. Work carefully, knocking off just the high spots. Once the panel is uniform, use a random orbit sander and 80-grit paper to begin the smoothing process. Work up through the grits to 180, sanding across the grain, then with the grain. You can also have your top sanded by a cabinet shop's wide belt-sanding machine for a nominal cost and save yourself the work. When the panel is smooth, use your table saw to cut it to width and a circular saw to cut it to length and square.

With the bench top finished, it's time to cut all the other pieces to width and length according to the *Material List* on page 124. While you're at it, cut some extra pieces to use for testing during the machining stages. Label everything carefully

QuickTip

Expanding Workspace Without Sacrificing Portability

Extending the working table of your power miter saw increases its accuracy and makes it easier to handle long stock safely. This workstation design, made of scrap plywood, maintains the saw's portability, whether you're working in the shop or on a jobsite. Use threaded inserts in the plywood base to fasten the saw securely to the table with bolts through the saw's foot holes. If you own a portable workbench, size the depth of the workstation so you can clamp it using the bench's top vise.

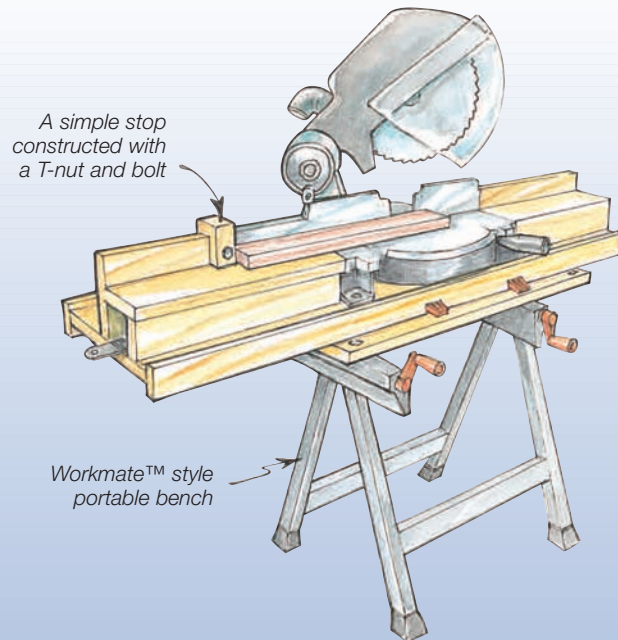

Arrange your bench top boards by alternating the growth-ring patterns. Number the boards so they stay in sequence and mark alternate "A's" and "O's" along the joint lines on the top face. With each board's top face away from the fence, joint the "A" edges. Then, with each board's top face on the fence, joint the "O" edges.

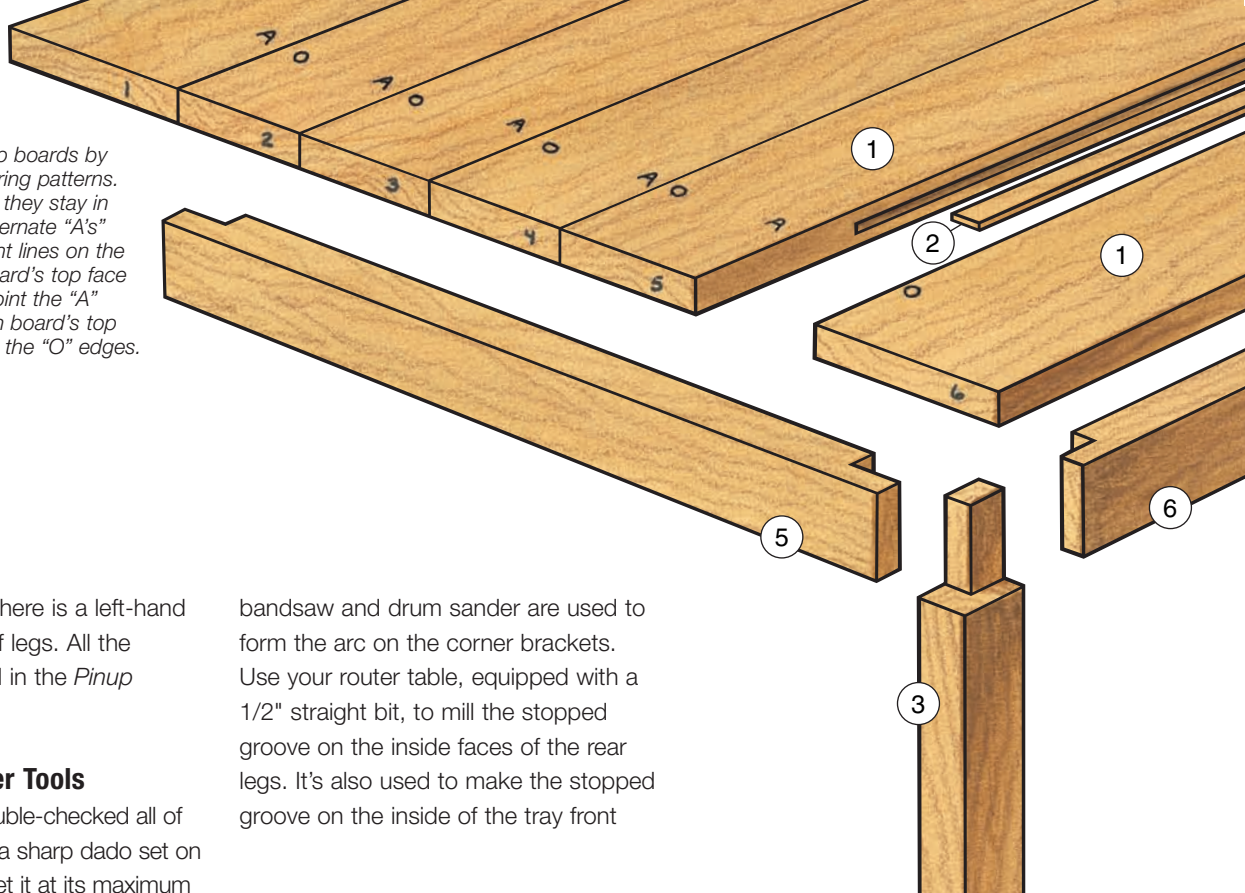

and remember that there is a left-hand and right-hand set of legs. All the details are presented in the *Pinup Shop Drawings*.

Fire Up Your Power Tools

Once you've double-checked all of your markups, install a sharp dado set on your table saw and set it at its maximum width. Since white oak has a tendency to splinter easily, stick masking tape over every marked dado to minimize tearout. After using some extra pieces of stock to test your settings, cut all the lap joints on the legs (pieces 3 and 4) and aprons (pieces 5, 6 and 7), as shown in *Figure 1*.

Stick with the dado set to cut the wide notch on the top front apron (this will later accommodate the tops of your flower pots), the notches on the two shelf boards (pieces 8), the tenon cheeks on the back boards (pieces 9 and 10) and the notches on the fronts of the tray runners (pieces 11). Finish up with the dado set by cutting the grooves in the runners.

Once you're finished with the dado set, use a miter saw to shape the mitered front apron and two side aprons (see *Figure 2*), as well as the taper at the tops of the rear legs. The miter saw is also the perfect tool for shaping the straight edges on the corner brackets (pieces 12). To make the six corner brackets stronger, follow the grain pattern when laying them out.

Before moving on to the jigsaw, make quick stops at the band saw, drum sander and router table. The

bandsaw and drum sander are used to form the arc on the corner brackets. Use your router table, equipped with a 1/2" straight bit, to mill the stopped groove on the inside faces of the rear legs. It's also used to make the stopped groove on the inside of the tray front

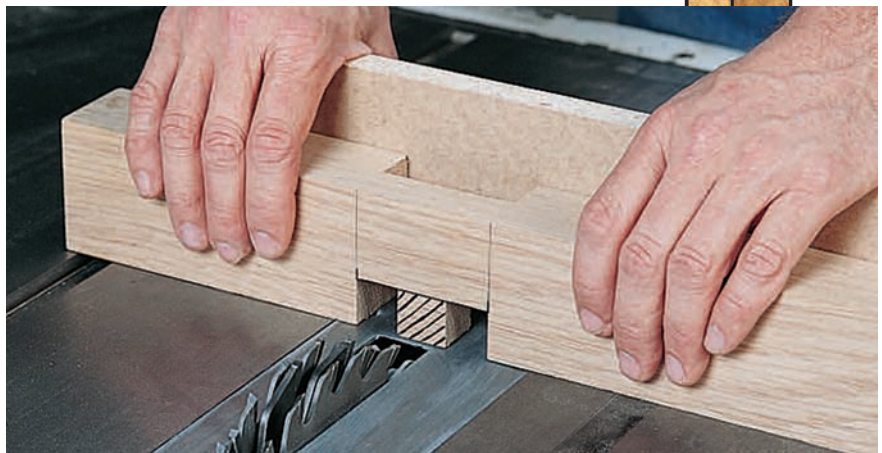
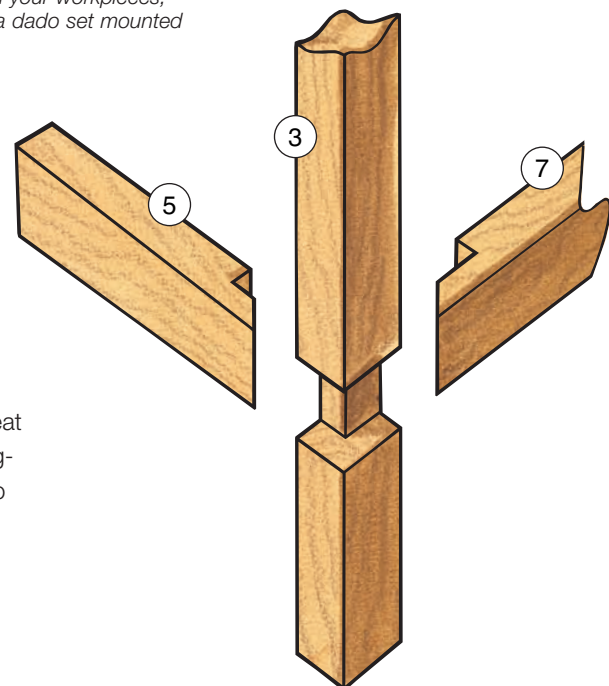

Figure 1: After you've carefully marked all your workpieces, cut the lap joints on the bench legs with a dado set mounted in your table saw.

(piece 13) as shown on the *Pinup Shop Drawings*.

Switch to a jigsaw to form the notches at the rear of the benchtop, allowing the top to wrap around the rear legs. Even though the top is 1 1/2" thick, a good jigsaw equipped with a sharp blade shouldn't work up a sweat cutting through white oak. Use the jigsaw to cut the hole for the mixing tub (piece 14) as well. Since you already have considerable time and money



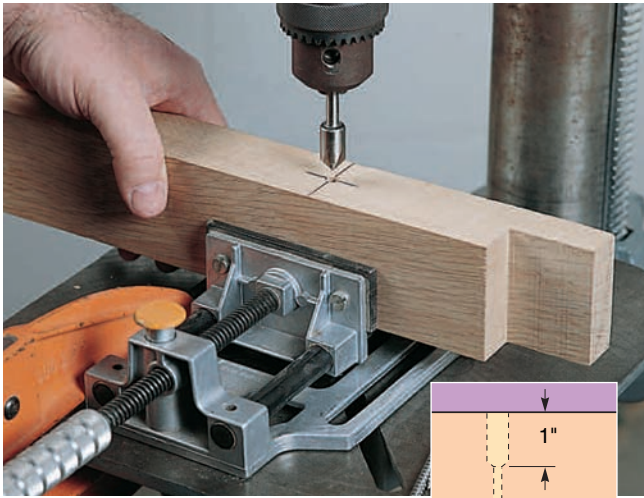
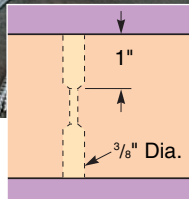

Figure 4: Drill the 1"-deep counterbores in the tops and bottoms of the aprons with a 3/8" countersink.



invested in the white oak top, purchase your tub (really just a plastic dishwashing pan) and cut a test hole in scrap before you tackle the white oak. Aim for a tight friction fit. The hole in our top measures 11½" x 13", but when we cut our test hole in some scrap plywood, the tub lip wouldn't hide square corners.

In order to prevent the cutout from dropping on your toes, cut three sides and then attach a scrap brace (see *Figure 3*) to the cutout with a couple of screws. The brace will also prevent the cutout from pinching your jigsaw blade as you cut the fourth side.

Now turn to your drill press, equipped with a circle cutter, to form the arcs on the top back board and the tray front. Adjust your drill press for 250 rpm and your cutter for a 3"-diameter circle. To eliminate tearout, clamp your boards down securely, cut halfway through and flip them over to finish the cut. A circle cutter forms a clean circle requiring little sanding, but if you don't have one, you could use a jigsaw and clean up the sawn edges with a drum sander.

Use the circle cutter for making the holes in the potting tray (piece 15). Again, check your flower pot sizes before you cut the holes. We outfitted ours for 4" and 6" standard clay pots, requiring 3/8" and 5/4" holes, respectively. No matter what size pots you buy, aim for a loose friction fit, and arrange them in a pattern that will allow you to remove a pot full of soil and fertilizer easily, even if you're wearing damp and dirty gardening gloves.

Creating Screw Holes that Give

A unique feature designed into this potting bench is the way the benchtop is attached to allow for wood movement. Basically, it consists of matching 1"-deep counterbores that allow the wide, thick benchtop to shift with the seasons (see *Figure 4*). An additional benefit of this design is that it allows you to use shorter exterior-grade screws—only 2½" long.

Mark the screw hole locations on the aprons and the

MATERIAL LIST

	T x W x L		T x W x L		
1	Bench Top (1)	1½" x 22¾" x 44"	13	Tray Front (1)	¾" x 5½" x 40"
2	Bench Top Splines (5)	¼" x ¾" x 38"	14	Mixing Tub (1)	Plastic Dishpan
3	Front Legs (2)	1¾" x 2½" x 34½"	15	Potting Tray (1)	¾" x 15¾" x 19½"
4	Rear Legs (2)	1¾" x 2½" x 50¼"	16	Shelf Stretcher (1)	1¾" x 2½" x 17½"
5	Side Aprons (4)	1¾" x 2½" x 21"	17	Tool Hangers (3)	¼" x 2" Dowel
6	Front & Rear Aprons (3)	1¾" x 2½" x 38¾"	18	Tray Spacer (1)	¾" x 2½" x 17½"
7	Mitered Front Apron (1)	1¾" x 2½" x 40"	19	Back Board Spacers (8)	½" x ½" x 1"
8	Shelf Boards (6)	1½" x 3⅝" x 40"	20	Leg Caps (2)	¼" x 1¾" x 2½"
9	Top Back Board (1)	¾" x 5½" x 36"	21	Potting Tray Cleat (1)	¾" x ¾" x 13½"
10	Lower Back Boards (3)	¾" x 2" x 36"	22	Screw Hole Plugs (15)	3/8" Dia. White Oak
11	Tray Runners (2)	1¾" x 4⅞" x 19¼"	23	Exterior-grade Screws (10)	#6 x 1¼"
12	Corner Brackets (6)	1¾" x ¾" x ¾"	24	Exterior-grade Screws (73)	#8 x 2½"

Bench Exploded View

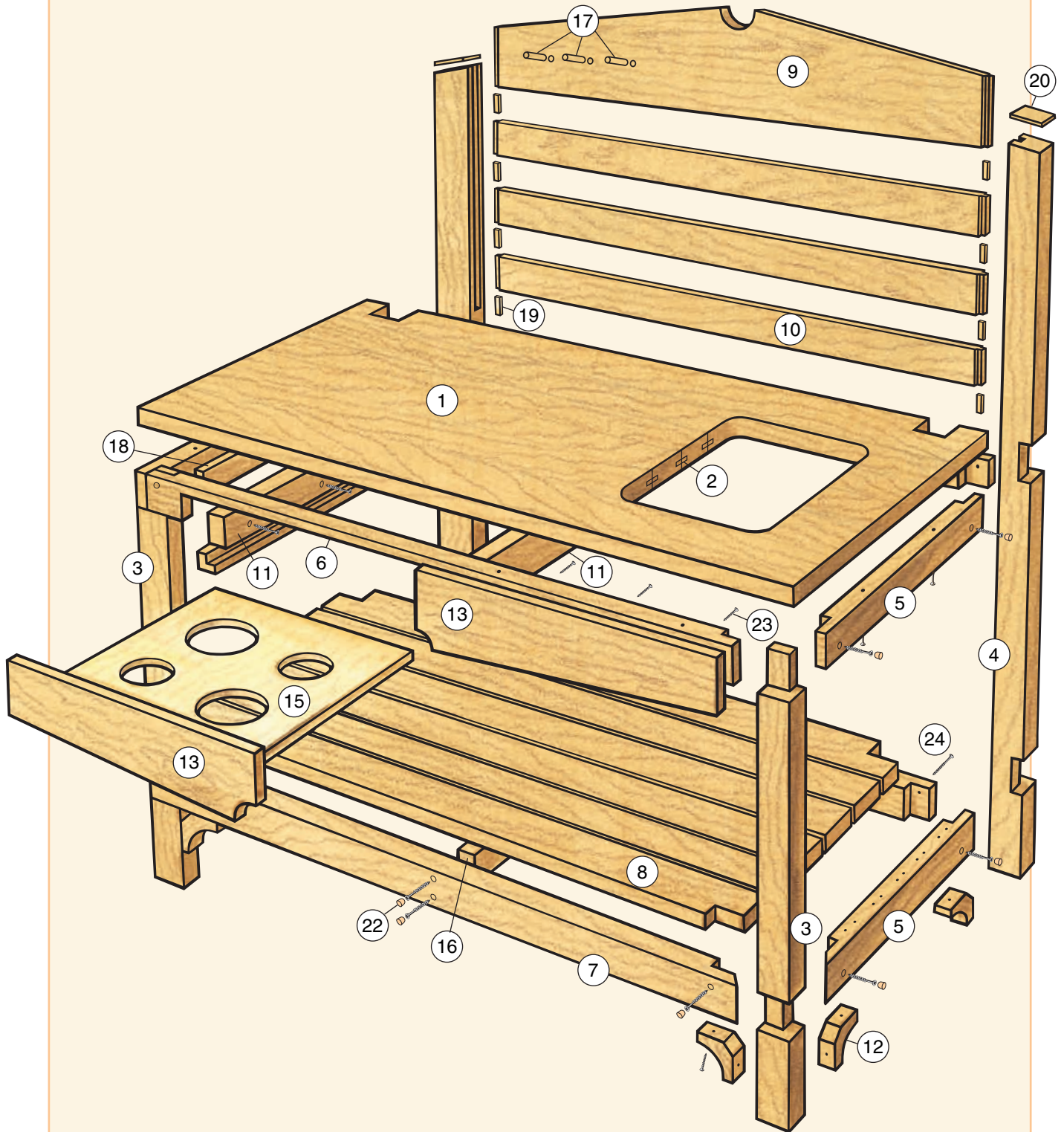

TWO EASY STEPS TO CUT THE TAPERS

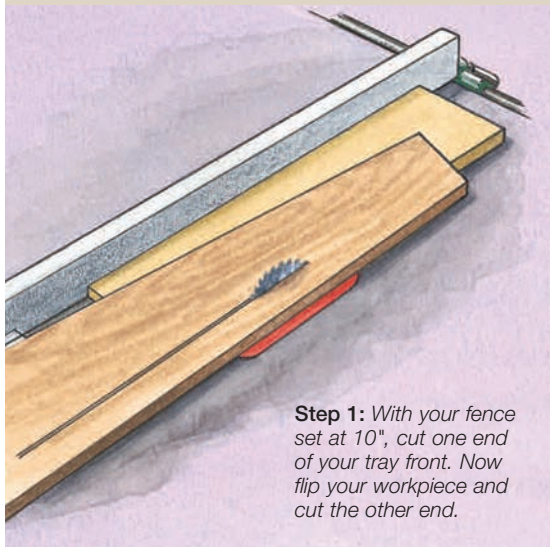

Step 1: With your fence set at 10°, cut one end of your tray front. Now flip your workpiece and cut the other end.

Cutting the tapers on the tray front and the top back board of the potting bench is easy with this simple jig, even though the tray front is 4" longer than the top back board. Cut the jig and spacer from 3/4" birch plywood, as shown in the illustration at left, using your table saw and jigsaw.

Now just follow the two-step process shown below.

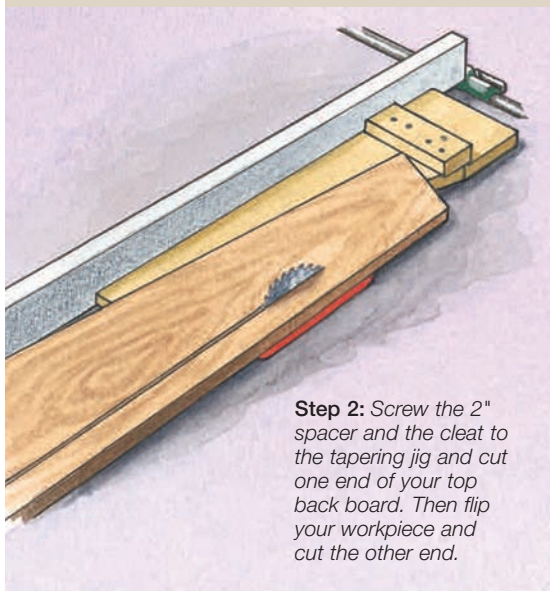

Step 2: Screw the 2" spacer and the cleat to the tapering jig and cut one end of your top back board. Then flip your workpiece and cut the other end.

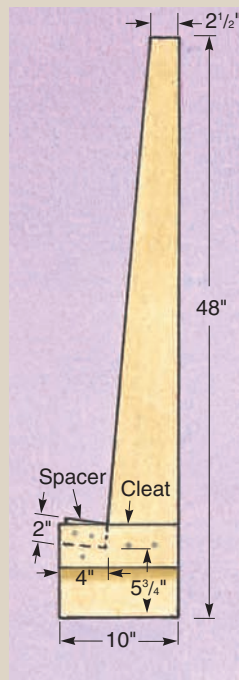

shelf stretcher (piece 16) as indicated on the *Pinup Shop Drawings*. With a 9/64" bit in your drill press and a fence set 7/8" from center, drill all the way through the aprons. Now switch to a 3/8" countersink and set your depth stop to form a 1"-deep counterbore.

Drill the holes on one edge of an apron and flip your workpiece to drill the matching holes, using the 9/64" pilot hole as a guide. Follow the same procedures on the rest of the aprons and the stretcher. Finish up on the drill press by cutting holes for the tool hangers

(pieces 17) at a 5° angle tipped upward on the top back board. This angle ensure that tools won't fall off the dowel pegs later.

Putting the Pieces Together

Now it's time to put the pieces together. With the help of some clamps, dry-assemble the legs and aprons, making sure everything fits precisely and the full assembly is square. Once you're satisfied, drill 1/8" pilot holes and 3/8" counterbores where they are marked on the *Pinup Shop Drawings*.

Now unclamp the dry assembly and call a buddy who can supply a couple of extra hands. Brush on water-resistant glue, then re-clamp and screw the pieces together. We used square-drive exterior screws for making these connections. Square-drive screws are finally becoming readily available at most lumber yards and hardware stores. Once you use them, you'll be sorely tempted to throw away every slotted or phillips screw you own. You'll need a square drive bit for installing these screws. Some manufacturers include a bit with the screws if you buy them in volume. We've found that square drive screws are worth every penny, simply because the design seldom if ever slips.

Once this assembly dries, glue and screw the tray spacer (piece 18) in place and attach the tray runners (see *Pinup Shop Drawings*).

Now tip the bench on its back to tackle the top and shelf. Clamp the top in place and use an awl to mark the locations of the screw holes (see *Figure 5*). Remove the top and drill the 1/8" pilot holes 1" deep, then replace the top and screw it in place. Follow the same procedure with the shelf boards, but first sand a roundover on the top edges. Attach the two notched shelf



Figure 5: With the top firmly clamped to the aprons, tip the bench on its back and mark the locations of the pilot holes with an awl.

boards first, and follow with the other four boards spaced an equal distance apart. As long as you have the bench on its back, now is a good time to glue and screw the corner brackets in place beneath the lower aprons.

Return the bench to an upright position and glue the spacers (pieces 19) and back boards—but not the top back board—in place. Dry-fit the top board just to make sure the taper you've marked on the board meets the top of the taper you've already cut on the rear legs.

Tapering the Top Back Board and Tray Front

The tapering jig that's described in the *sidebar* on the preceding page is different than most jigs because it will cut the same taper on boards of different lengths. With this project, we wanted the arcs and tapers to match, even though the top back board is four inches shorter than the tray front.

Cut the taper on the top back board and glue it in place. The tool hangers are glued in place along with the leg caps (pieces 20), which protect the end grain of the rear legs and cover the grooves cut for the back board tenons.

Cut the tray front in half. Screw—

but don't glue—the left half to the potting tray, using the tray cleat (piece 21) and 1¼" exterior-grade screws. Don't glue the plywood tray in place so you can easily replace it when necessary after a few seasons of use. Slide this half into the tray runners and then glue and screw the right half to the front apron, making sure that it lines up with the left half.

Finishing Up

Cut 3/8"-diameter screw hole plugs (pieces 22) from white oak using a tapered plug cutter (see *Figure 6*). Glue the plugs in the screw holes on the front and side surfaces and use a sharp chisel to pare them evenly with the surrounding surface.

Sand the project with 80, 120 and 180-grit papers before applying two coats of satin spar marine varnish,



Figure 6: You can cut your own screw hole plugs with a 3/8" plug cutter in your drill press. Cut the plugs loose by resawing to 3/8" on your band saw.

sanding lightly with 180-grit paper between coats to ensure good adhesion. Your potting bench is now ready for many seasons of good use. Renew the topcoat with another layer of varnish every few years.

QuickTip

Nailing a Sticky Situation

Unless you use your glue regularly, you've probably experienced the hassle of "skimmed-over" bottles of glue from time to time. Here's one trick for extending your glue's life: simply insert a tight-fitting nail in the spout and slowly turn it upside down, sealing the air out of the area of the spout inside the bottle. If the bottle still has a good spout, squeeze out as much air as possible and skip the nail. Then store the bottle upside-down in a coffee can. This way, any glue "skin" that may still form will end up on the bottom of the bottle when you turn the glue upright again, which won't clog the nozzle. Also, be sure to store your glue in a warm environment at all times to keep it from freezing; if you have a garage shop, bring your glue indoors during the winter months.